

# Bollard 300

Unique twin directional pathway light (GU10)



Copper



Stainless Steel

## General Information

The Bollard 300 lens reflects light at two angles through an anti-glare mesh directly onto the ground and horizontally to illuminate the surrounding landscape.

The Bollard 300 is ideal for exterior lighting such as driveways, path lighting, parking areas.

## IP Rating

IP66

## Light Source - GU10 6w LED Lamp

Input 90-260 volt, 5 watts

## Colour Temperature

3000k

## Lamp Life

Up to 30,000 hours

## Finishes

Copper

316L Stainless Steel

Powder Coated Aluminium:

-  Hawthorn Green
-  Olive Green
-  Bronze
-  Black
-  Dark Grey
-  Silver Star
-  White

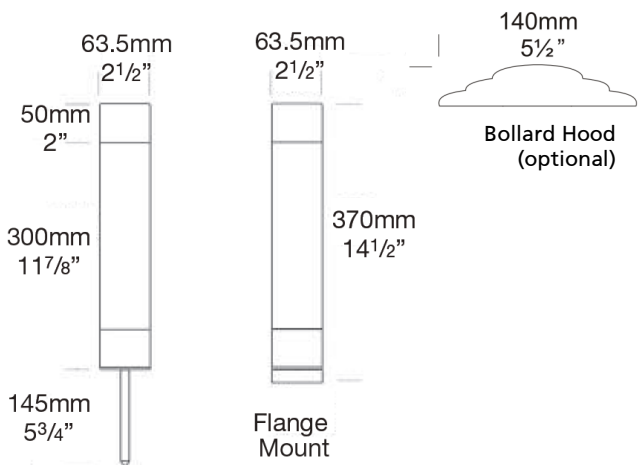

Optional 300mm ground spike, flange mounted as standard

## Options

Cable Joint Kit - CJK150

(available in single kits or packs of 5)

Bollard Hood - BGH

Spike mounting (300mm) as standard - 300

Internal flange mount

External flange mount

The colour chart shown should be used as a guide only as your monitor and printer settings may alter the colours.